

• • • • •  
ACCESSORI PER  
EQUILIBRATICI







• • • • •  
ACCESSORIES FOR  
WHEEL BALANCERS

Valido dal 03/2011







# Indice

## EM







-  Centraggio “a coni” per ruote auto con foro centrale preciso ( $\text{Ø}42\div173\text{mm}$ ) ..... 4
-  Centraggio “a boccole” per ruote auto con foro centrale preciso, consigliato dai costruttori d’auto ..... 5
-  Centraggio “a flange universali autocentranti” per ruote auto di tipo chiuso e aperto, a 3-4-5-6-8 fori ( $\text{Ø}$  di foratura  $90\div210\text{mm}$ ) ..... 6
-  Accessorio Racing per ruote sportive, aventi distanza fra piano di appoggio del cerchio e lato interno ruota maggiore di 170mm ..... 7
-  Autocentrante universale per ruote moto ..... 8
-  Accessori moto specifici ..... 9

## ET





-  Centraggio “a coni” per ruote camion e autobus con foro centrale ( $\text{Ø}159\div281\text{mm}$ ) ..... 10
-  Centraggio “a boccia a gradini” per ruote camion e autobus con foro centrale ( $\text{Ø}160\div280\text{mm}$ ) ..... 11
-  Centraggio “a flange TRILEX” per cerchioni privi di flangia ..... 12
-  Centraggio “a coni” per ruote auto, fuoristrada e furgoni con foro centrale preciso ( $\text{Ø}47\div165\text{mm}$ ) ..... 13
-  Centraggio “a flangia universale autocentrante” per ruote di tipo chiuso e aperto a 3, 4, 5, 6 e 8 fori ( $\text{Ø}$  di foratura  $90\div210\text{mm}$ ) ..... 14

# Index

## EM

-  Cones centering for car wheels with definite centre hole ( $\text{Ø}42\div 173\text{mm}$ ).....4
-  Bushings centering for car wheels with definite centre hole, suggested by car manufacturers.....5
-  Self centering universal flanges centering for close and open centre car wheels with 3-4-5-6-8 holes (P.C.D.  $90\div 210\text{mm}$ ) .....6
-  Racing accessory for sport car wheels having distance between rim plate and internal wheel side higher than 170mm.....7
-  Universal motorcycle adapter.....8
-  Specific motorcycle adapters.....9

## ET

-  Cones centering for truck and bus centre hole wheels ( $\text{Ø}159\div 281\text{mm}$ ) ..... 10
-  Steps bushing centering for truck and bus centre hole wheels ( $\text{Ø}160\div 280\text{mm}$ ) ..... 11
-  TRILEX flanges centering for “no hub” rims ..... 12
-  Cones centering for car, 4x4 and light commercial vehicle wheels with definite centre hole ( $\text{Ø}47\div 165\text{mm}$ ) ..... 13
-  Self centering universal flanges centering for close and open centre car wheels with 3, 4, 5, 6 and 8 holes (P.C.D.  $90\div 210\text{mm}$ )..... 14

# Centraggio "a coni" per ruote auto con foro centrale preciso ( $\text{Ø}42\div173\text{mm}$ )

## Cones centering for car wheels with definite centre hole ( $\text{Ø}42\div173\text{mm}$ )

- — Auto
- — Cars
- ..... Furgoni - Fuoristrada
- ..... Light commercial vehicle - 4x4

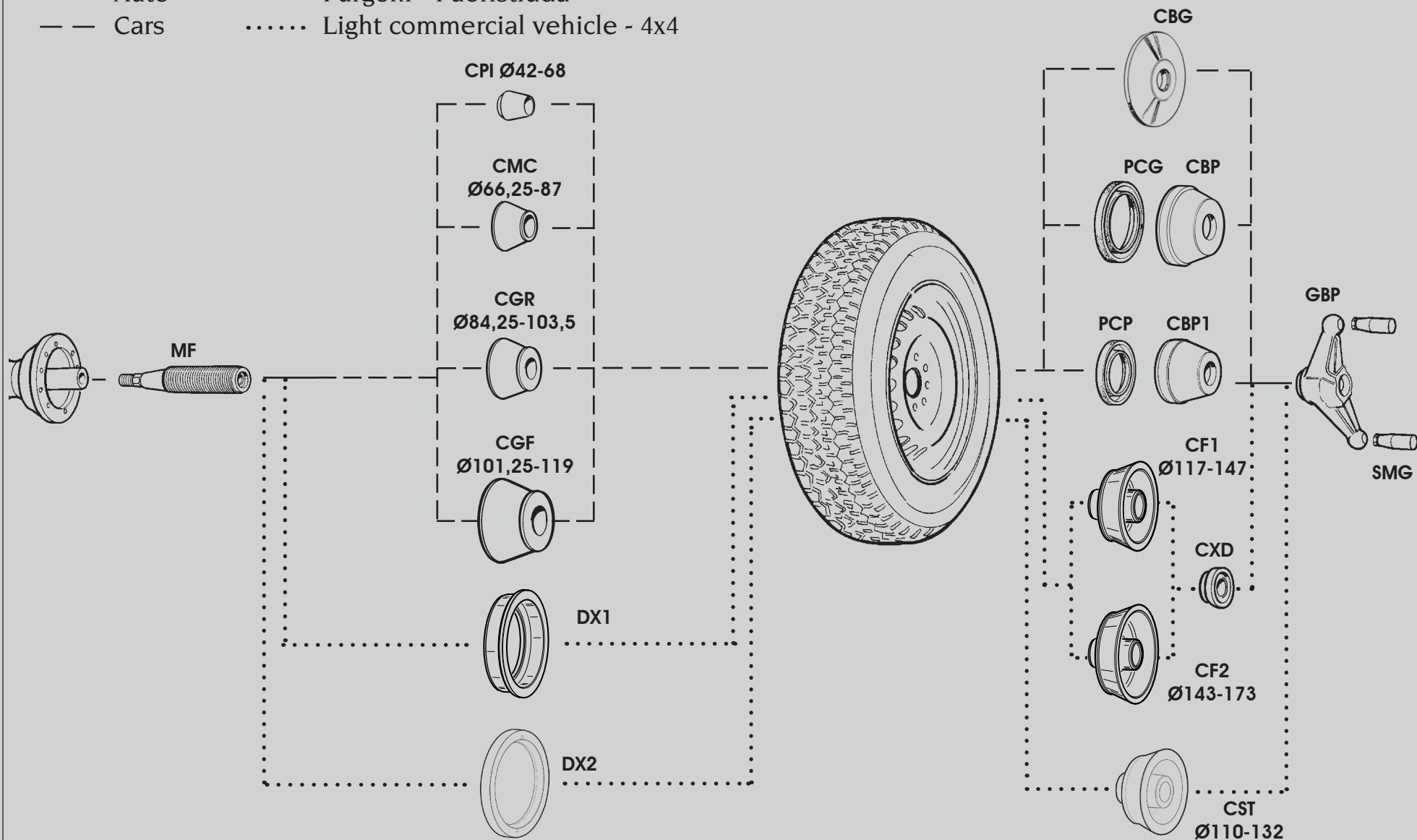

## Centraggio "a boccole" per ruote auto con foro centrale preciso, consigliato dai costruttori d'auto

### Bushings centering for car wheels with definite centre hole, suggested by car manufacturers

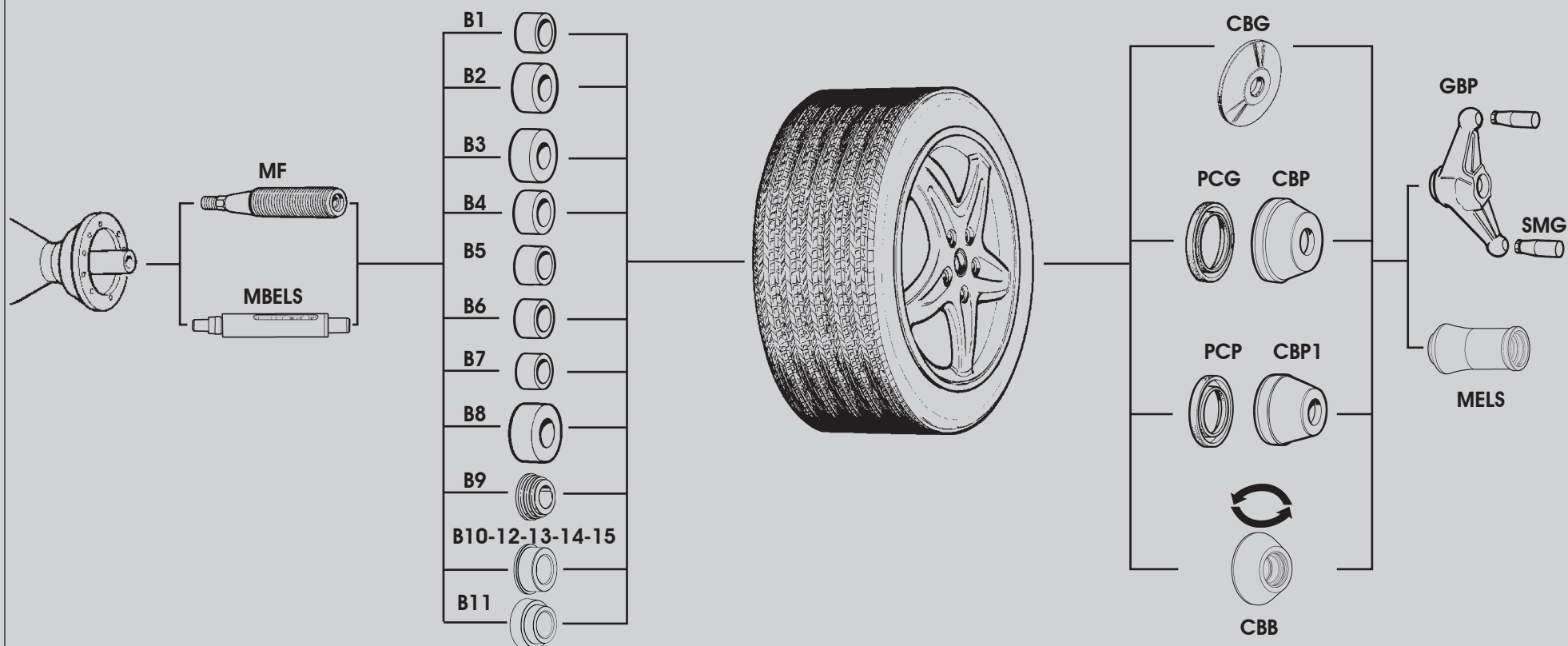

<b>B1</b> (Ø56,5-57,1)	AUDI, BMW, Chrysler, Opel, Rover, Seat, VW, Daewoo, Galaxy (Ford), Lotus, British-Leyland, Smar (Mercedes), Skoda.
<b>B2</b> (Ø65-67)	Citröen, Hyundai, Lancia, Maserati, Mazda, Mercedes, Mitsubishi, Nissan, Opel, Peugeot, Saab, Volvo.
<b>B3</b> (Ø73,2-75,4)	BMW, Jaguar, Aston Martin.
<b>B4</b> (Ø63,3-64,2)	Ford, Honda, Rover.
<b>B5</b> (Ø58-60,1)	Autobianchi, Alfa Romeo, Citröen, Fiat, Lada, Lancia, Jalbot, Biturbo (Maserati), Mazda, Nissan, Peugeot, Porsche, Renault, 2600-3600 serie (Rover), Seat =>90, Skoda, Toyota.
<b>B6</b> (Ø67)	Boccola Racing ø67 (Ferrari, Maserati) - <i>Racing bushing ø67 (Ferrari, Maserati).</i>
<b>B7</b> (Ø54-56,1)	Citröen, Daihatsu, Honda, Kia, Mazda, Mitsubishi, Peugeot, Rover, Subaru, Toyota, Agilla (Opel), Suzuki, Hyuday.
<b>B8</b> (Ø74,6)	BMW serie 5 cerchi 17" 99 =>.
<b>B9</b> (Ø56,5-65-70,1)	Boccola omologata Opel. - <i>Opel approved bushing.</i>
<b>B10-B12-B13-B14-B15</b>	Boccole omologate Renault. - <i>Renault approved bushings.</i> (Ø60, Ø66, Ø71, Ø89, Ø130)
<b>B11</b> (Ø56-57/72,5-74)	Boccola omologata BMW, Mini, Range Rover (=>04) - <i>BMW, Mini, Range Rover (=&gt;04) approved bushing.</i>



**Centraggio "a flange universali autocentranti" per ruote auto di tipo chiuso e aperto, a 3-4-5-6-8 fori  
(Ø di foratura 90÷210mm)**

**Self centering universal flanges centering for close and open centre car wheels with 3-4-5-6-8 holes (P.C.D. 90÷210mm)**

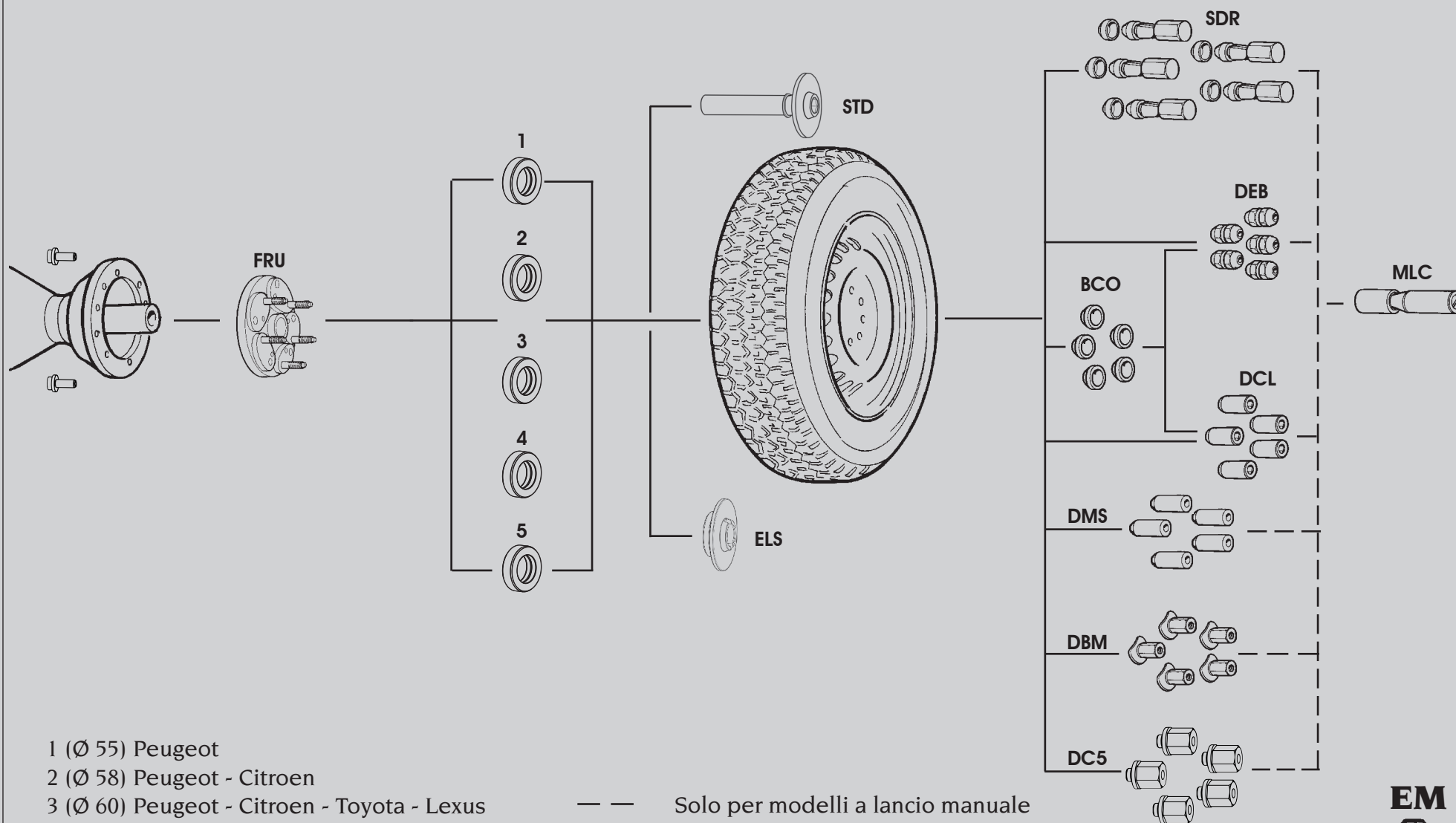

- 1 (Ø 55) Peugeot
- 2 (Ø 58) Peugeot - Citroen
- 3 (Ø 60) Peugeot - Citroen - Toyota - Lexus
- 4 (Ø 65) Peugeot - Citroen - Opel - Volvo
- 5 (Ø 57) BMW - Volkswagen - Audi - Seat

— — Solo per modelli a lancio manuale  
 — — Only for hand spin models



## Accessorio Racing per ruote sportive

### Racing accessory for sport car wheels

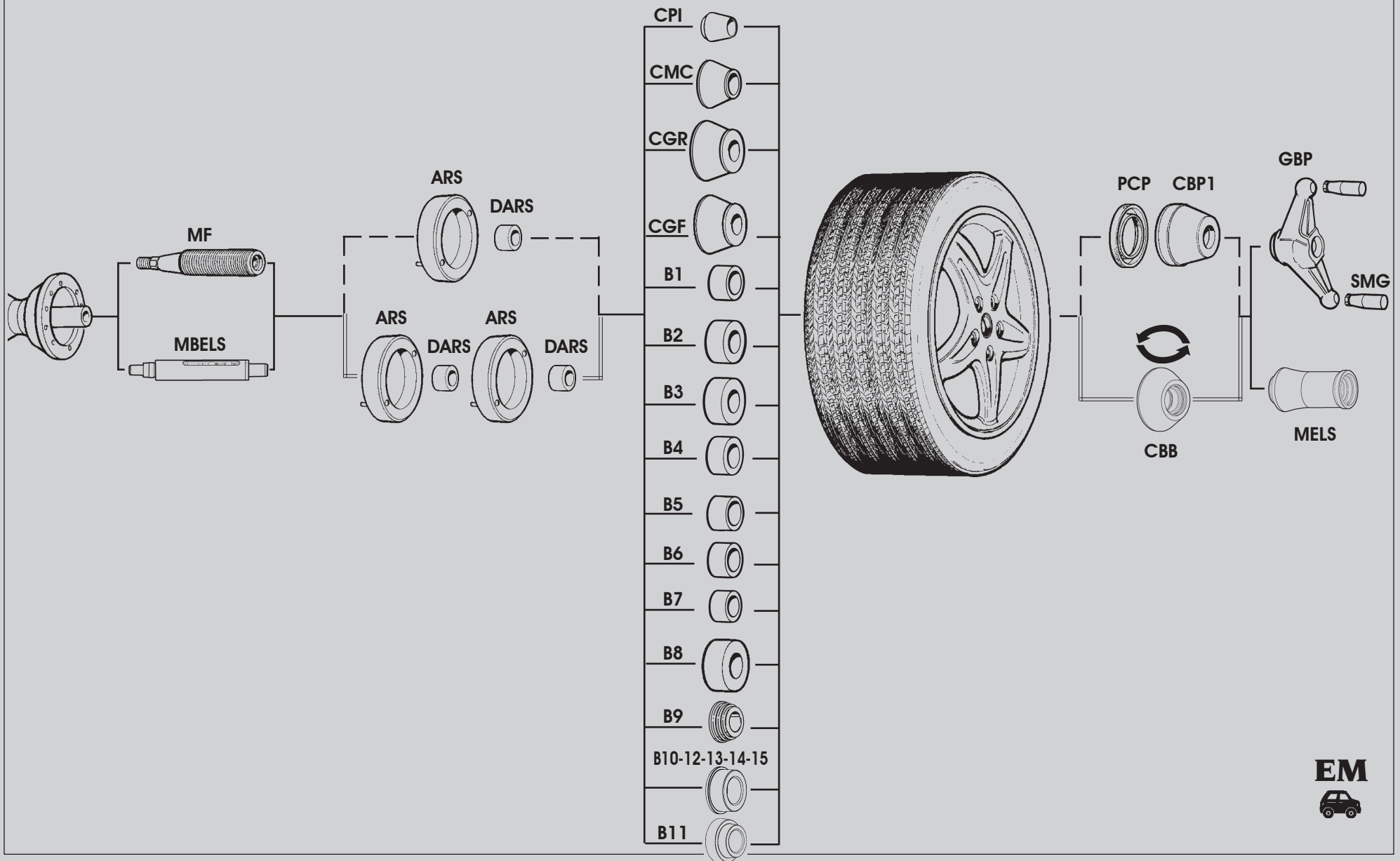

# Autocentrante universale per ruote moto Universal motorcycle adapter

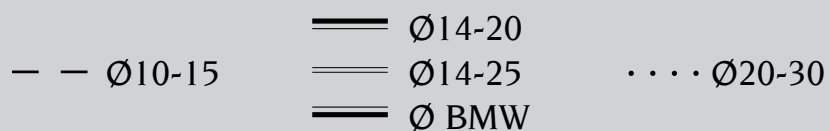
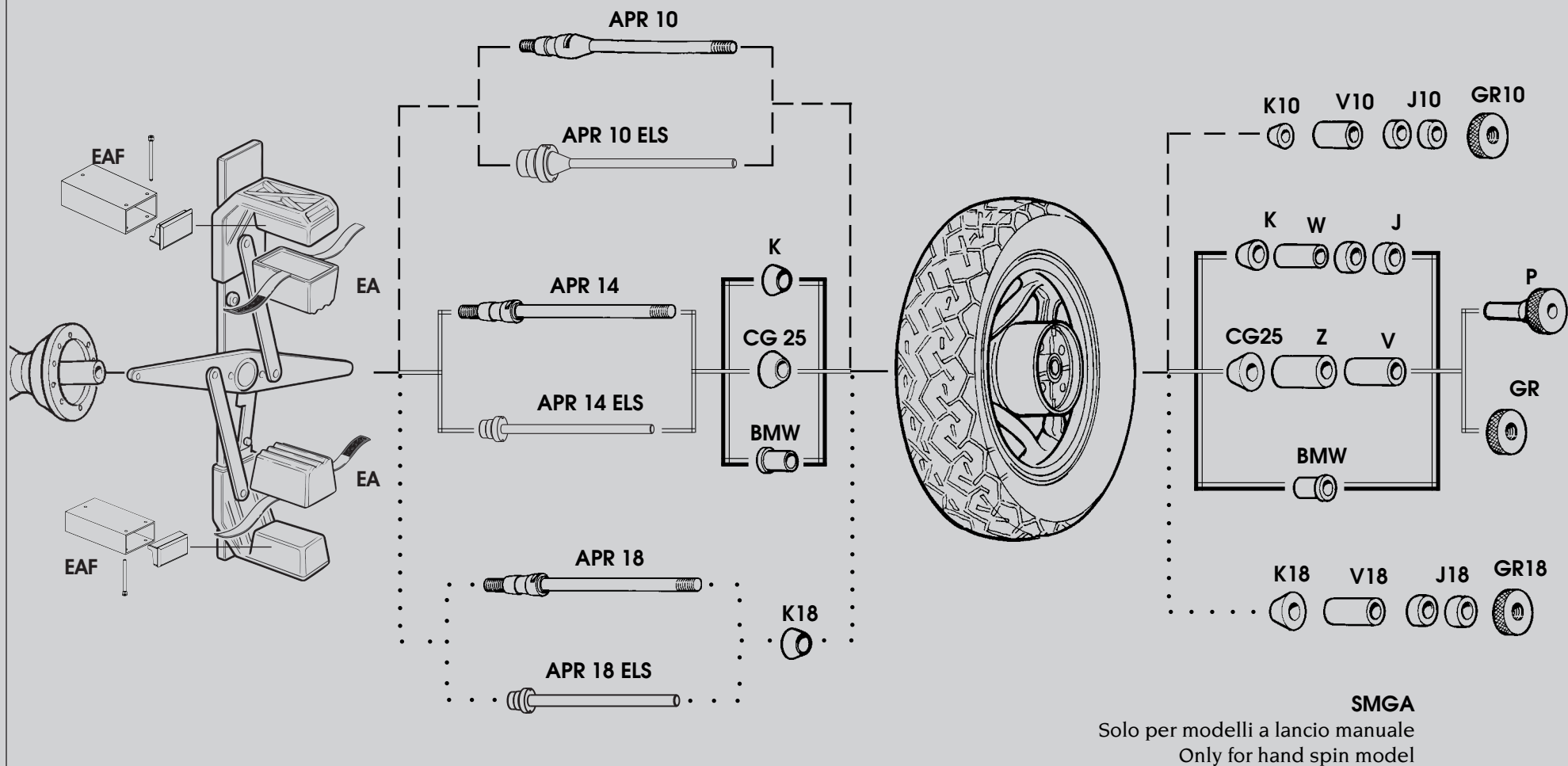



# Centraggio "a coni" per ruote camion e autobus con foro centrale (Ø159÷281mm) Cones centering for truck and bus centre hole wheels (Ø159÷281mm)

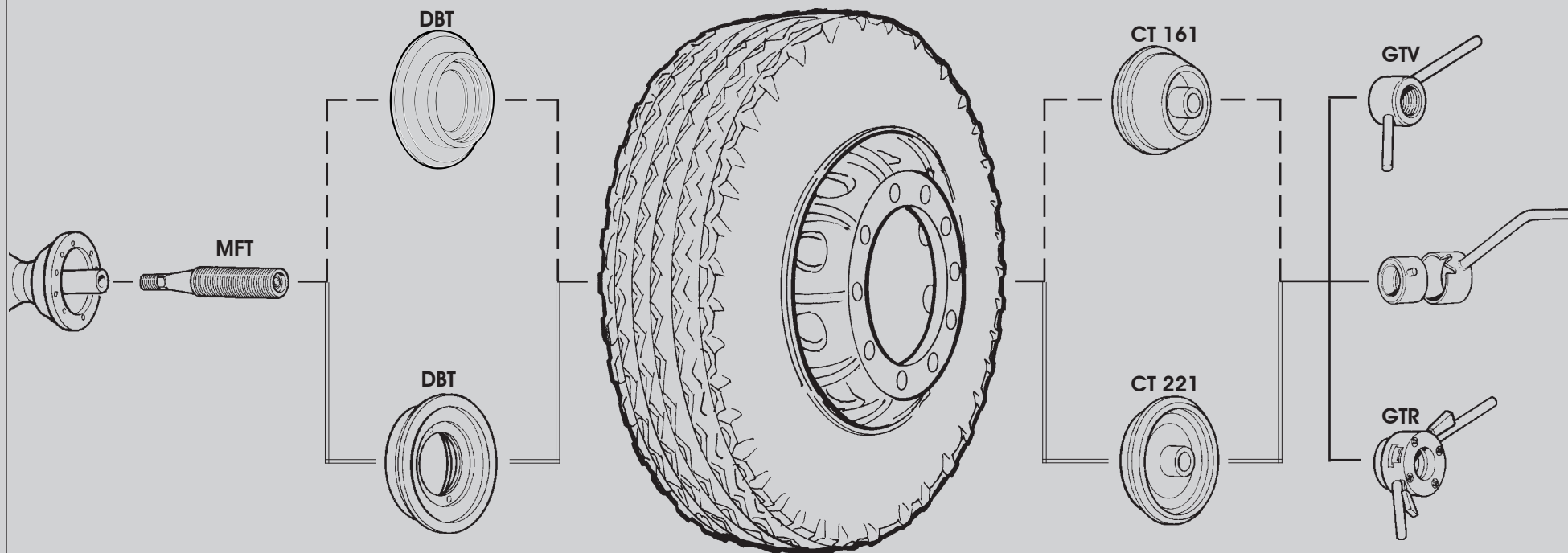

— Ø159-281

- - Ø159÷180/198÷204

==== Ø220-281



**Centraggio “a boccola a gradini” per ruote camion e autobus con foro centrale (Ø160÷280mm)**  
**Steps bushing centering for truck and bus centre hole wheels (Ø160÷280mm)**

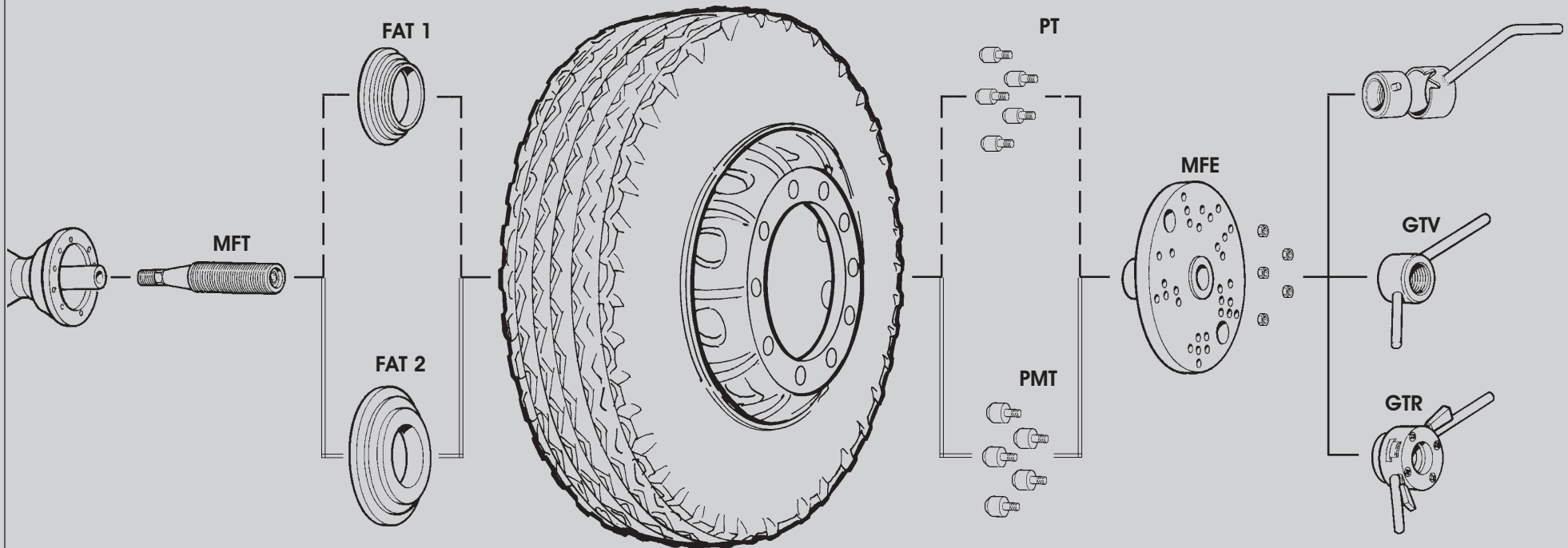

— Ø160-280      - - - Ø160-176-200      = = = Ø220-280



## Centraggio "a flange TRILEX" per cerchi privi di flangia TRILEX flanges centering for "no hub" rims

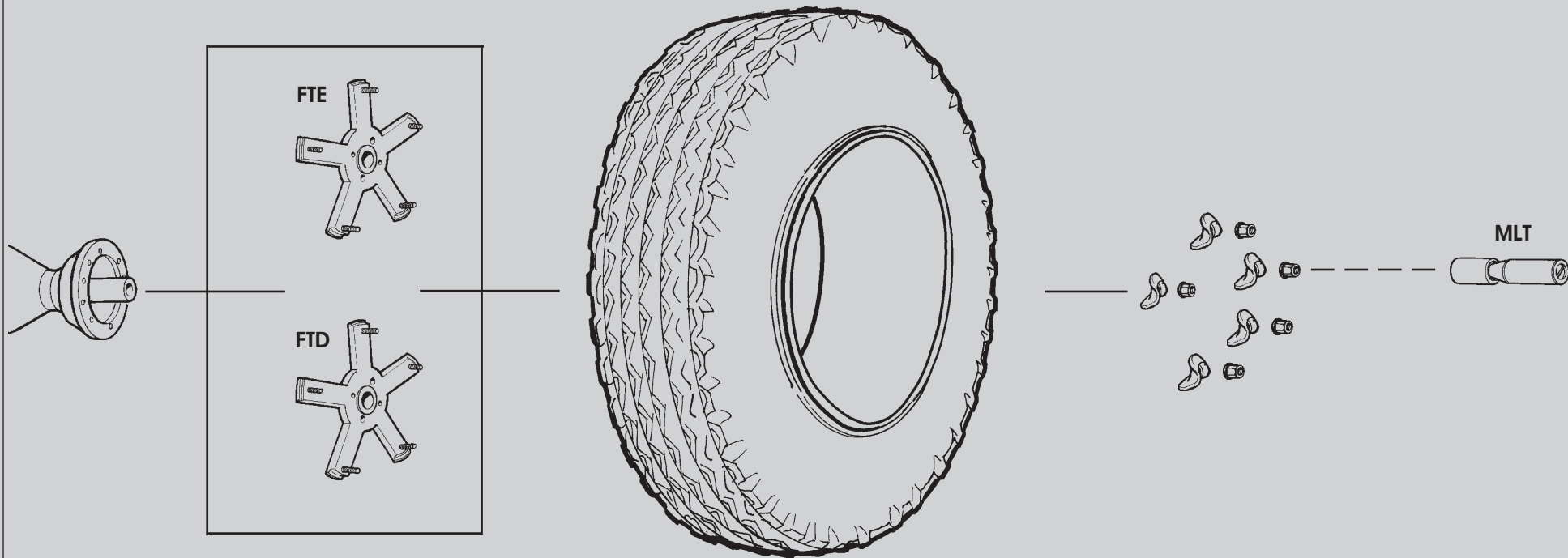

- — Solo ET 66
- — ET 66 only



**Centraggio "a cono" per ruote auto, fuoristrada e furgoni con foro centrale preciso (Ø47÷165mm)**  
**Cones centering for car, 4x4 and light commercial vehicle wheels with definite centre hole (Ø47÷165mm)**

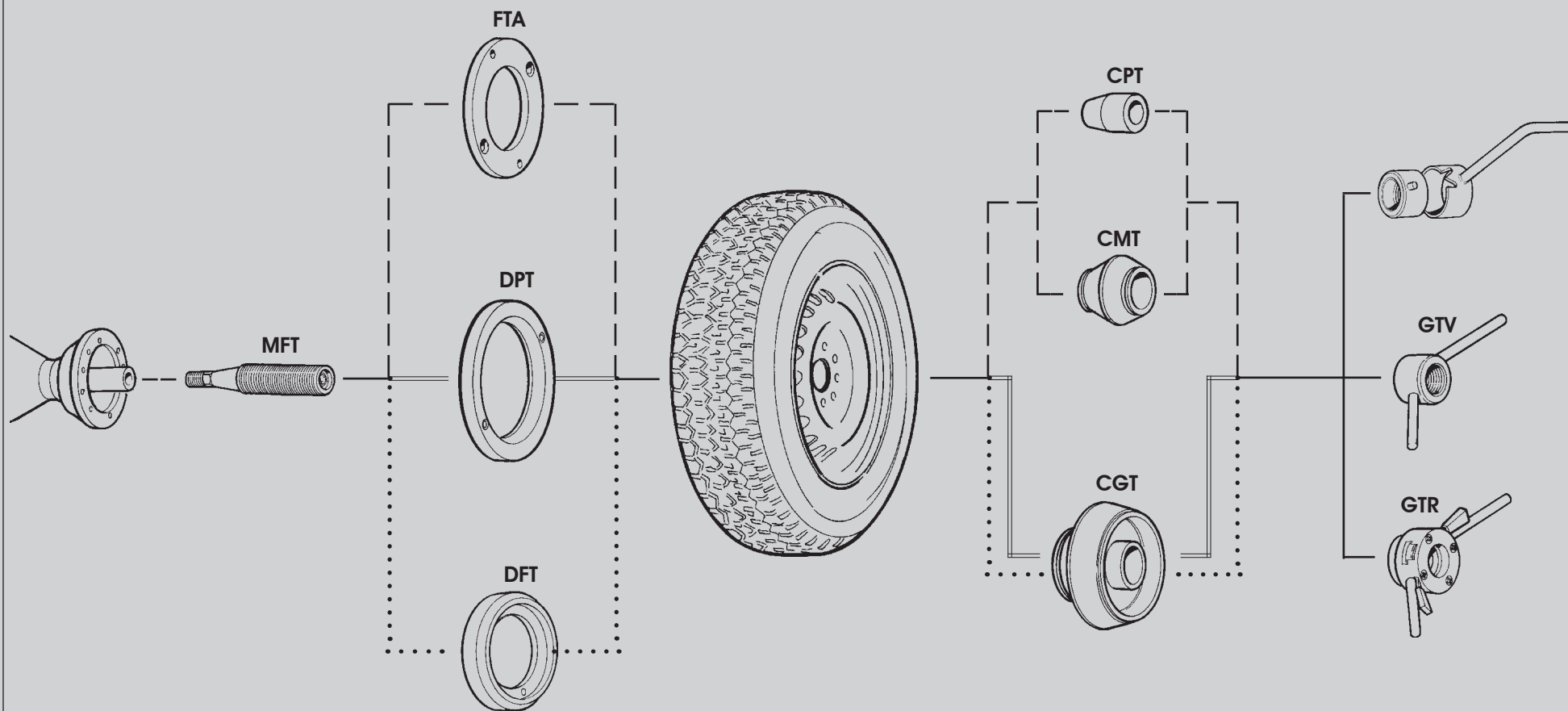

— — Auto  
 — — Cars

==== Fuoristrada e furgoni  
 ==== 4x4 and light commercial vehicles

..... Ford 350/450  
 ..... Ford 350/450



**Centraggio "a flangia universale autocentrante" per ruote di tipo chiuso e aperto a 3, 4, 5, 6 e 8 fori  
(Ø di foratura 90÷210mm)**

**Self centering universal flanges centering for close and open centre car wheels with 3, 4, 5, 6 and 8 holes (P.C.D. 90÷210mm)**

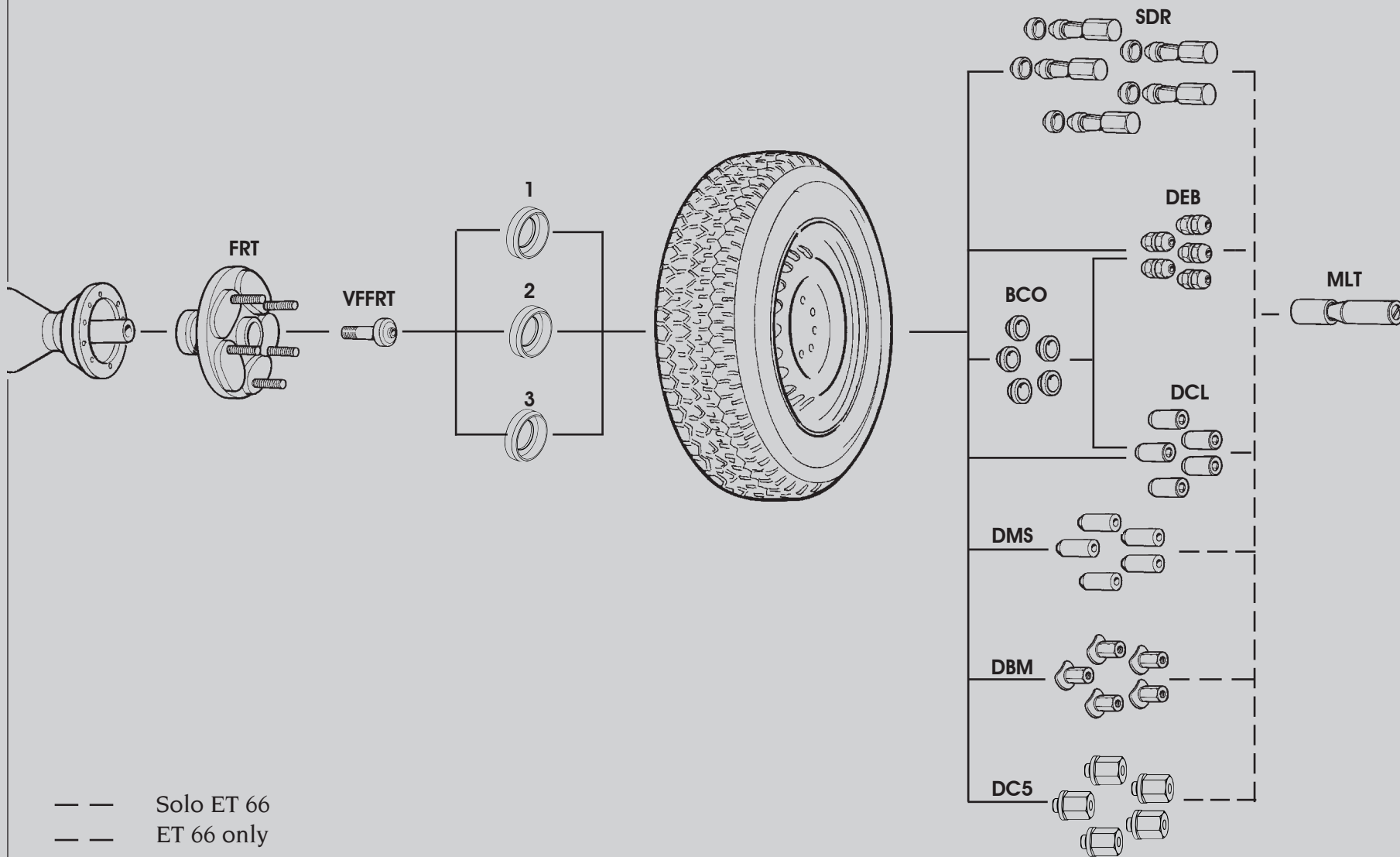



ACCESSORI PER  
EQUILIBRATICI

ACCESSORIES FOR  
WHEEL BALANCERS



CORGHI S.p.A. - Strada Statale 468 n.9  
42015 CORREGGIO - R.E. - ITALY  
Tel. ++39 0522 639.111 - Fax ++39 0522 639.150  
[www.corgchi.com](http://www.corgchi.com) - [info@corgchi.com](mailto:info@corgchi.com)