

ERCO 3002 CBP



Ponte sollevatore elettromeccanico ribassato con basamento



Electro-mechanical lift with base, low profile



Elektromechanische hebebühne mit Tragkonstruktion, niedrige Ausführung



Pont élévateur électro-mécanique avec embase, version surbaissée



Elevador electro-mecánico con basamento, version rebajada



Plataforma eletro-mecânica com base, versão abaixada

DATI TECNICI / TECHNICAL DATA / TECHNISCHE DATEN / DONNÉES TECHNIQUES / DATOS TÉCNICOS / ESPECIFICAÇÕES TÉCNICAS

Portata max.	Max. capacity	Tragfähigkeit max.	Portée max.	Capacidad máxima	Capacidade max	kg	3000
Potenza motore	Electric motor power	Motorleistung	Puissance du moteur	Potencia motor	Potência do motor	Kw	3,6 (400V 3ph 50Hz)
Alimentazione	Power supply	Stromversorgung	Alimentation	Alimentación	Alimentação		230-400V 3ph 50-60Hz

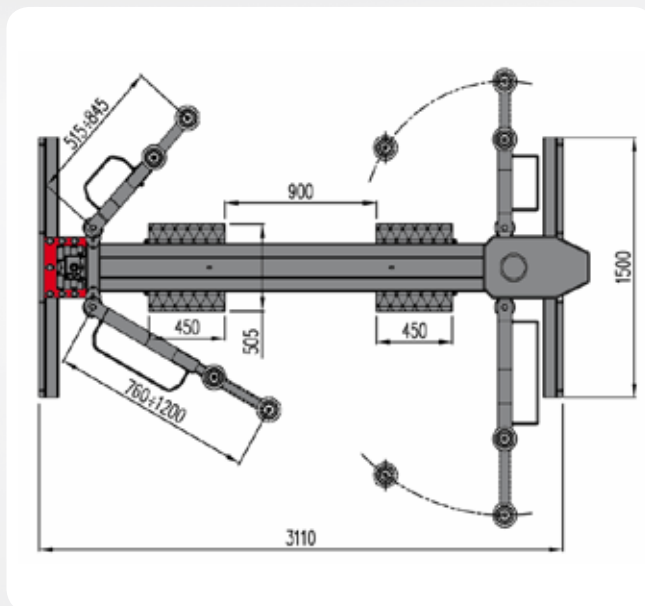
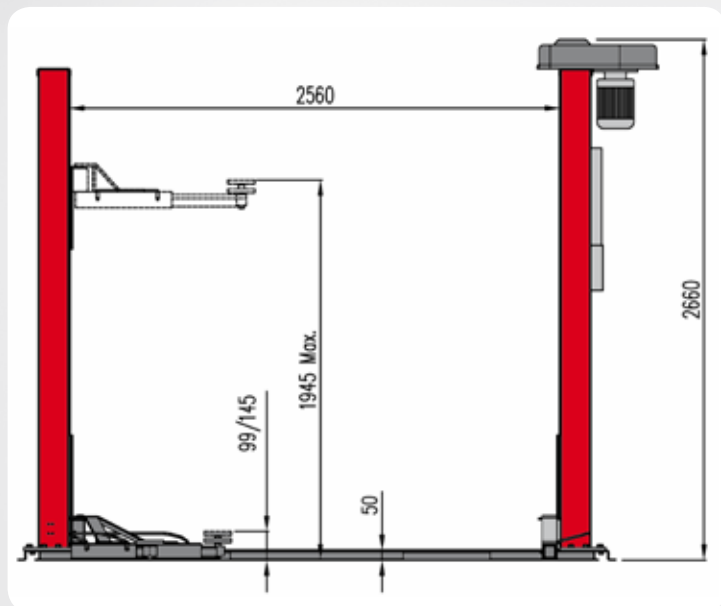

Caratteristiche tecniche

- Colonne: alta rigidità
- Carrelli: su guide GSM (BM)
- Bracci: intercambiabili
- Catena: doppia guida
- Basamento: smontabile
- Fine corsa: protetti
- Controllo usura chiocciola

- Autocontrollo su:
 - catena
 - carrelli
 - bracci
 - piedini regolazione colonne

A richiesta

- Serie prolunghe tamponi
- Tamponi a forbice



Technical characteristics

- Columns: high rigidity
- Carriages: on GSM (BM) guides
- Arms: interchangeable
- Chain: double guide
- Basement: demountable
- Limit switches: protected
- Female-screw wear control

- Automatic control of:
 - chain
 - carriages
 - arms
 - columns adjustment legs

On request

- Set of extension pads
- Mini scissor pad



Technische Eigenschaften

- Säulen: hohe Steifheit
- Hubschlitten: auf GSM(BM) Führungen
- Armen: austauschbar
- Kette: doppelführung
- Grundrahmen: zerlegbar
- Endschalter: geschützt
- Schnecke-Verschleisskontrolle
- Automatische Kontrolle von:
 - kette
 - schlitten
 - armen
 - Säuleneinstellfüsse



Caractéristiques techniques

- Colonnes: haute rigidité
- Chariots: sur guides GSM(BM)
- Bras: interchangeables
- Chaîne: guide double
- Base: démontable
- Fin-de-courses: protégés
- Contrôle usure écrou
- Contrôle automatique de:
 - chaîne
 - chariots
 - bras
 - pieds de réglage colonnes

Sur demande

- Série de rallonge tampons
- Ciseaux tampon



Características técnicas

- Columnas: alta rigidez
- Carros: sobre guías GSM (BM)
- Brazos: intercambiables
- Cadena: guía doble
- Basamento: desmontable
- Finales de carrera: protegidos
- Control usura tuerca
- Control automático de:
 - cadena
 - carros
 - brazos
 - pies reglaje columnas

Opcionales

- Serie de alargador tampones
- Tampón el apoyo a tijera



Características técnicas

- Colunas: alta rigidez
- Carros: em guias GSM (BM)
- Braços: intercambiáveis
- Corrente: guia dupla
- Embasamento: desmontable
- Fim de cursos: protegidos
- Controle usura porca
- Controle automático da:
 - corrente
 - carros
 - braços
 - pés reglagem colunas

Opcionais

- Conjunto extensão tampão
- Tampão com o apoio do pinça

Fotografie, caratteristiche ed i dati tecnici non sono vincolanti, possono subire modifiche senza preavviso. The manufacturer reserves the right to modify the features of its products at any time. Les photographies, les caractéristiques et les données techniques ne sont pas contraignantes. Le fabricant se réserve le droit d'apporter des modifications sans préavis. Fotografien, Eigenschaften und technische Daten sind nicht bindend und können ohne Vorankündigung geändert werden. Las fotografías, las características y los datos técnicos no son vinculantes. La empresa se reserva el derecho de modificaciones en cualquier momento. As fotografias, as características e os dados técnicos não são vinculantes, podem ser modificados sem prévio aviso. Code DP6000271 04/2010

Per aiutare il pianeta ottimizzando il consumo di carta, i nostri cataloghi sono consultabili sul sito www.corghi.com. Una stampa responsabile aiuta a preservare l'ambiente. To protect the planet and reduce paper usage, our catalogues are viewable online at the website www.corghi.com. Printing responsibly contributes to saving the environment.

