







ERCO 300

 **CORGHI**
Made in Italy



-  Pedane di sollevamento elettroidrauliche
-  *Electro-hydraulic scissors lift*
-  Elektrohydraulische scherenhebebühne
-  *Plate-forme de levage électrohydraulique*
-  Plataforma de elevación electrohidráulica
-  *Plataformas elevatórias electro-hidráulica*

 **CORGHI**
seguí Corghi - follow Corghi

ERCO 300 P - ERCO 300 T

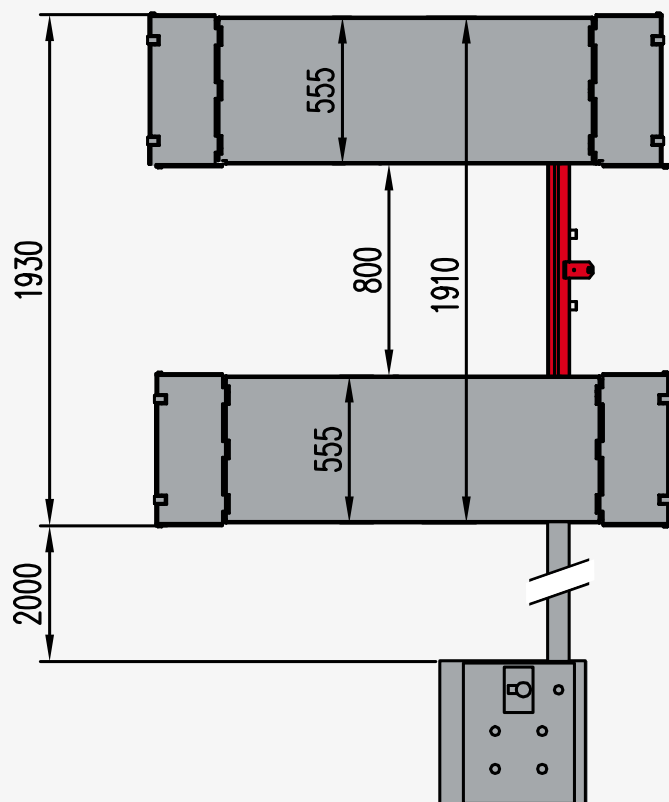
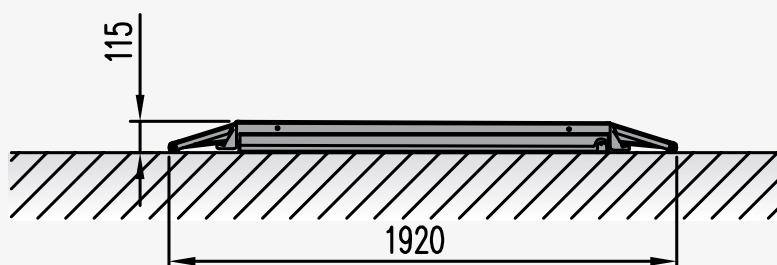
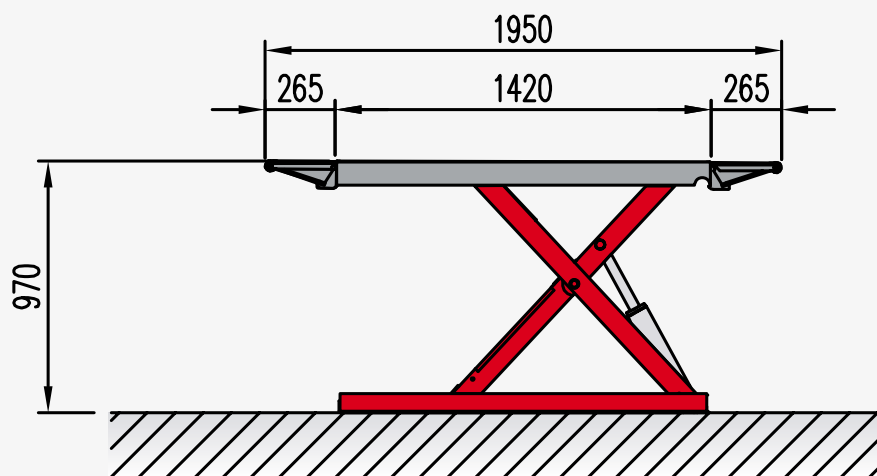

Caratteristiche tecniche

- Funzionamento elettroidraulico
- Sicure elettromeccaniche di stazionamento
- Dispositivo salvapiedi elettrico
- Comandi 24V bassa tensione
- Boccola autolubrificante su tutti i movimenti
- Autoallineamento delle pedane con barra di torsione
- Uso molto semplice



Technical characteristics

- Electro-hydraulic functioning
- Electro-mechanical safety locking devices
- Electrically operated foot guard
- 24V low voltage controls
- Self-lubricating bush on all moving parts
- Self-alignment platforms with torsion bar
- Very easy to use



Technische Eigenschaften

- Elektrohydraulische Funktionsweise
- Elektromechanische Sicherheitseinrichtung
- Elektrische Fußschutzeinrichtung
- 24V - Niederstromsteuerung
- Selbstschmierende Lager an allen beweglichen Teilen
- Automatische Nivellierung der Plattform mit Torsionsstab
- Sehr einfache Bedienung

ERCO 300 I

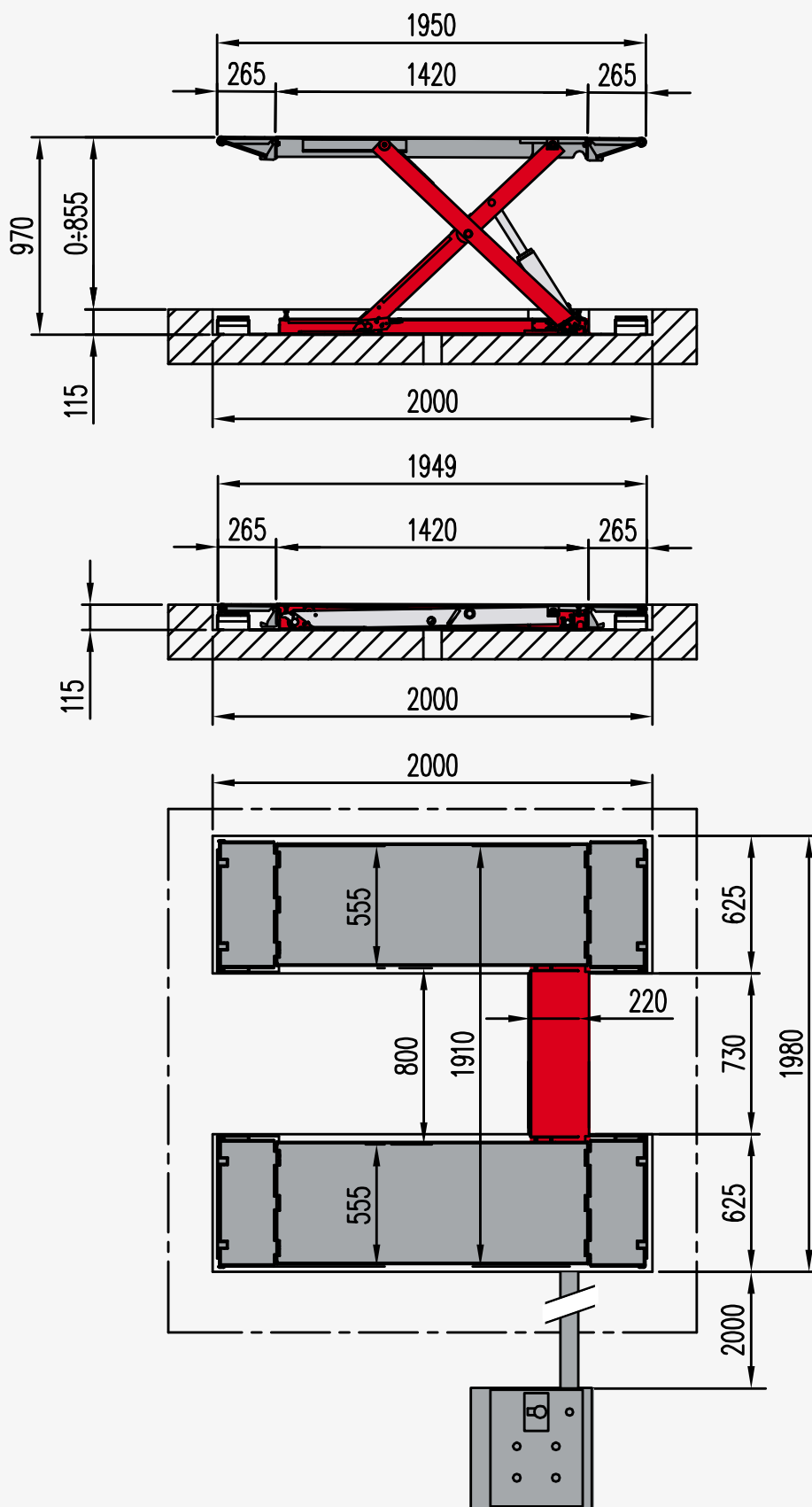

Caractéristiques techniques

- Fonctionnement électrohydraulique
- Sécurités électromécanique de stationnement
- Dispositif électrique de protection des pieds
- Commandes 24V basse tension
- Bague lubrifiée à vie sur tous les mouvements
- Alignement automatique des rampes avec barre de torsion
- Extrême simplicité d'utilisation



Características técnicas

- Funcionamiento electrohidráulico
- Dispositivos de seguridad electromecánicos de estacionamiento
- Dispositivo eléctrico para evitar lesiones en los pies
- Mandos 24V baja tensión
- Casquillo autolubricante en todos los movimientos
- Autoalineación de las plataformas con barra de torsión
- Uso muy sencillo



Características técnicas

- Funcionamento electro-hidráulico
- Trancas de segurança eletromecânicas de pausa
- Protecção dos pés operada electricamente
- Comandos 24V baixa tensão
- Casquilhos auto-lubrificantes em todas as partes móveis
- Auto-alinhamento dos tabladros com barra de torção
- Uso muito simples

DATI TECNICI / TECHNICAL DATA / TECHISCHE DATEN / DONNÉES TECHNIQUES / DATOS TÉCNICOS / ESPECIFICAÇÕES TÉCNICAS

Portata max.	Max capacity	Tragfähigkeit max.	Portée max.	Capacidad máxima	Capacidade max	kg	3000
Tempo di salita	Lifting time	Hubzeit	Temps de montée	Tiempo de subidar	Tempo de subida	s	20
Tempo di discesa	Lowering time	Senkzeit	Temps de descente	Tiempo de bajada	Tempo de descida	s	30
Potenza motore	Electric motor power	Motorleistung	Puissance du moteur	Potencia motor	Potência do motor	kw	2,6 (400V 3ph 50Hz)
Alimentazione	Power supply	Stromversorgung	Alimentation	Alimentación	Alimentação		230-400V 3ph 50-60Hz 230V 1ph 50Hz



Dotazioni di serie

- Serie di 4 tamponi H=40mm

A richiesta

- Serie di 4 tamponi H=60mm H=120
- Coppia di traverse e tamponi per veicoli fuoristrada
- Kit prolunga tubi
- Pompa manuale di emergenza
- Kit 4 rampe per vetture con "spoiler"



Standard equipment

- Set of rubber pads H=40mm

On request

- Set of 4 rubber pads H=60mm H=120
- Pair of cross-beams and pads for off-road vehicles
- Pipeline extension kit
- Emergency hand pump
- cars with spoilers



Serienmäßige Ausstattung

- Set mit 4 Auflagekissen aus Hartgummi (40mm)

Sonderzubehör

- Set mit 4 Auflagekissen aus Hartgummi (60-120mm)
- Paar Querträger und Auflagekissen für Geländewagen
- Rohrverlängerungs-Set
- Manuelle Notpumpe
- Set mit 4 Rampen für KFZ mit "Spoiler"



Equipement de serie

- Série de 4 tampons en caoutchouc (40mm)

Sur demande

- Série de 4 tampons en caoutchouc (60-120mm)
- Paire de traverses et de tampons pour véhicules tout-terrains
- Kit rallonge tuyaux
- Pompe manuelle d'urgence
- Kit 4 rampes pour voitures avec « spoiler »



Dotación de serie

- Serie de 4 tampones de goma (40mm)

Opcionales

- Serie de 4 tampones de goma (60-120mm)
- Par de travesaños y tampones para vehículos todoterreno
- Kit alargador tubos
- Bomba manual de emergencia
- Kit 4 rampas para coches con spoiler



Dotações de série

- Conjunto 4 tampão em borracha (40mm)

Opcionais

- Conjunto 4 tampão em borracha (60-120mm)
- Par de travessa e tampão para veículos off-road
- Extensão kit tubo
- Bomba manual de emergência
- Kit 4 rampas para carros com spoilers

Fotografie, caratteristiche ed i dati tecnici non sono vincolanti, possono subire modifiche senza preavviso. The manufacturer reserves the right to modify the features of its products at any time. Les photographies, les descriptions et les données techniques ne sont pas contraignantes. Le fabricant se réserve le droit d'apporter des modifications sans préavis. Fotografieren, Eigenschaften und technische Daten sind nicht bindend und können ohne Vorankündigung geändert werden. Las fotografías, las características y los datos técnicos no son vinculantes. La empresa se reserva el derecho de modificarlos en cualquier momento. As fotografias, as características e os dados técnicos não são vinculantes, podem ser modificados sem prévio aviso. Code: DP6G000273 04/2010

Per aiutare il pianeta ottimizzando il consumo di carta, i nostri cataloghi sono consultabili sul sito www.corghi.com. Una stampa responsabile aiuta a preservare l'ambiente. To protect the planet and reduce paper usage, our catalogues are viewable online at the website www.corghi.com. Printing responsibly contributes to saving the environment.



ERCO 300 T
Versione mobile - Mobile version



OPTIONAL



Rampa salita lunga - Long ramps

Rampa salita corta - Short ramps

Per i dati tecnici d'installazione, caratteristiche del suolo, carichi trasmessi a terra e tipo di ancoraggi fare riferimento al manuale d'uso.



CORGI S.p.A. a NEXION GROUP COMPANY - Strada Statale 468 n° 9 - 42015 CORREGGIO - R.E. - ITALY
Tel. ++39 0522 639.111 - Fax ++39 0522 639.150 - www.corgi.com - info@corgi.com